



Designation: D3608 – 19

Standard Test Method for Nitrogen Oxides (Combined) Content in the Atmosphere by the Griess-Saltzman Reaction¹

This standard is issued under the fixed designation D3608; the number immediately following the designation indicates the year of original adoption or, in the case of revision, the year of last revision. A number in parentheses indicates the year of last reapproval. A superscript epsilon (ϵ) indicates an editorial change since the last revision or reapproval.

1. Scope

1.1 This test method covers the manual determination of the combined nitrogen dioxide (NO₂) and nitric oxide (NO) content, total NO_x; in the atmosphere in the range from 4 to 10 000 µg/m³ (0.002 to 5 ppm (v)).

1.2 The maximum sampling period is 60 min at a flow rate of 0.4 L/min.

1.3 The values stated in SI units are to be regarded as standard. The values given in parentheses are for information only.

1.4 *This standard does not purport to address all of the safety concerns, if any, associated with its use. It is the responsibility of the user of this standard to establish appropriate safety, health, and environmental practices and determine the applicability of regulatory limitations prior to use.*

1.5 *This international standard was developed in accordance with internationally recognized principles on standardization established in the Decision on Principles for the Development of International Standards, Guides and Recommendations issued by the World Trade Organization Technical Barriers to Trade (TBT) Committee.*

2. Referenced Documents

2.1 *ASTM Standards:*²

[D1071 Test Methods for Volumetric Measurement of Gaseous Fuel Samples](#)

[D1193 Specification for Reagent Water](#)

[D1356 Terminology Relating to Sampling and Analysis of Atmospheres](#)

[D1357 Practice for Planning the Sampling of the Ambient Atmosphere](#)

[D3195 Practice for Rotameter Calibration](#)

¹ This test method is under the jurisdiction of ASTM Committee D22 on Air Quality and is the direct responsibility of Subcommittee D22.03 on Ambient Atmospheres and Source Emissions.

Current edition approved March 1, 2019. Published April 2019. Originally approved in 1977. Last previous edition approved in 2011 as D3608 – 95 (2011). DOI: 10.1520/D3608-19.

² For referenced ASTM standards, visit the ASTM website, www.astm.org, or contact ASTM Customer Service at service@astm.org. For *Annual Book of ASTM Standards* volume information, refer to the standard's Document Summary page on the ASTM website.

[D3609 Practice for Calibration Techniques Using Permeation Tubes](#)

[D3631 Test Methods for Measuring Surface Atmospheric Pressure](#)

[E1 Specification for ASTM Liquid-in-Glass Thermometers](#)

[E128 Test Method for Maximum Pore Diameter and Permeability of Rigid Porous Filters for Laboratory Use](#)

3. Terminology

3.1 *Definitions*—For definitions of terms used in this test method, refer to Terminology [D1356](#).

4. Summary of Test Method

4.1 The NO is quantitatively (**1**)³ converted to NO₂ by a chromic acid oxidizer. The resulting NO₂, plus the NO₂ already present, are absorbed in an azo-dye-forming reagent (**2**). A red-violet color is produced within 15 min, the intensity of which is measured spectrophotometrically at 550 nm.

5. Significance and Use

5.1 Both NO₂ and NO play an important role in photochemical-smog-forming reactions. In sufficient concentrations NO₂ is deleterious to health, agriculture, materials, and visibility.

5.2 In combustion processes, significant amounts of NO may be produced by combination of atmospheric nitrogen and oxygen; at ambient temperatures, NO can be converted to NO₂ by oxygen and other atmospheric oxidants. Nitrogen dioxide also may be generated from processes involving nitric acid, nitrates, the use of explosives, and welding.

6. Interferences

6.1 Any significant interferences due to sulfur dioxide (SO₂) should be negated by the oxidation step. The addition of acetone to the reagent retards color-fading by forming a temporary addition product with SO₂. This will protect the reagent from incidental exposure to SO₂ and will permit reading the color intensity within 4 to 5 h (instead of the 45 min required without acetone) without appreciable losses.

³ The boldface numbers in parentheses refer to a list of references at the end of this standard.

6.2 A five-fold ratio of ozone to NO_2 will cause a small interference, the maximal effect occurring in 3 h. The reagent assumes a slightly orange tint.

6.3 The interferences from nitrous oxide and nitrogen pentoxide, and other gases that might be found in polluted air are considered to be negligible.

7. Apparatus

7.1 *Sampling Probe*—A glass or TFE-fluorocarbon (preferred) tube, 6 to 10 mm in diameter, provided with a downward-facing intake (funnel or tip). The dead volume of the system should be kept minimal, to avoid loss of NO_x on the surfaces of the apparatus.

7.2 *Oxidizer Tube*—Soak 14 to 16-mesh firebrick or $\frac{1}{16}$ -in. (1.5 mm) molecular sieve pellets in a 17 % aqueous solution of chromium trioxide (CrO_3) for 10 to 30 min. After draining the excess solution and drying in an oven at 105°C for 30 min, the solid oxidizer has a dull pink color. This color changes to rich yellow (active color) after 24-h equilibration with ambient air at 40 to 70 % relative humidity, or after drawing ambient air through at a flow rate of 0.5 L/min for 1 h. A change in color to a greenish brown indicates the exhaustion of oxidizing ability, and progresses with a sharp boundary. Place about 3 g of the oxidizer in a 30-mL midget impinger, or fill a 5-mm tube to a height of 80 mm and plug each end with glass wool.

7.3 *Absorber*—An all-glass bubbler with a 60- μm maximum pore diameter frit, commonly labeled “coarse,” similar to that illustrated in Fig. 1.

7.3.1 The porosity of the fritted bubbler, as well as the sampling flow rate, affect absorption efficiency. An efficiency of over 95 % may be expected with a flow rate of 0.4 L/min or less and a maximum pore diameter of 60 μm . Frits having a maximum pore diameter less than 60 μm will have a higher efficiency, but will require an inconvenient pressure drop for sampling.

7.3.2 Measure the porosity of an absorber in accordance with Test Method E128. If the frit is clogged or visibly discolored, carefully clean with concentrated chromic-sulfuric acid mixture, rinse well with water, and redetermine the maximum pore diameter.

7.3.3 Rinse the bubbler thoroughly with water and allow to dry before using.

7.4 *Mist Eliminator or Gas Drying Tube* filled with activated charcoal or soda lime is used to prevent damage to the flowmeter and pump.

7.5 *Air-Metering Device*—A calibrated glass variable-area flowmeter, or dry gas meter coupled with a flow indicator capable of accurately measuring a flow of 0.4 L/min is suitable.

7.6 *Thermometer*—ASTM Thermometer 33C, meeting the requirements of Specification E1, will be suitable for most applications of the method.

7.7 *Manometer*, accurate to 670 Pa (0.20 in. Hg).

7.8 *Air Pump*—A suction pump capable of drawing the required sample flow for intervals of up to 60 min.

7.9 *Spectrophotometer or Colorimeter*—A laboratory instrument suitable for measuring the intensity of the red-violet color at 550 nm, with stoppered tubes or cuvettes. The wavelength band-width is not critical for this determination.

7.10 *Stopwatch or Timer*.

8. Reagents and Materials

8.1 *Purity of Reagents*—Reagent grade chemicals shall be used in all tests. All reagents shall conform to the specifications of the Committee on Analytical Reagents of the American Chemical Society, where such specifications are available.⁴ Other grades may be used, provided it is first ascertained that the reagent is of sufficiently high purity to permit its use without lessening the accuracy of the determination.

8.2 *Purity of Water*—Water shall be deionized water in accordance with Specification D1193 for Type I and II reagent water. Water must be nitrite-free.

8.3 *Absorbing Reagent*—Dissolve 5 g of anhydrous sulfanilic acid (or 5.5 g of the monohydrate) in almost a litre of water containing 140 mL of glacial acetic acid. Gentle heating is permissible to speed up the process. To the cooled mixture, add 20 mL of the 0.1 % stock solution of *N*-(1-naphthyl)ethylenediamine dihydrochloride and 10-mL acetone. Dilute to 1 L. The solution will be stable for several months if kept well-stoppered in a brown bottle in the refrigerator. The absorbing reagent must be at room temperature before use. Avoid lengthy contact with air during both preparation and use, since absorption of nitrogen dioxide will discolor the reagent.

8.4 *Chromic Acid Oxidant*—Dissolve 17 g of chromium trioxide (CrO_3) in 100 mL of water.

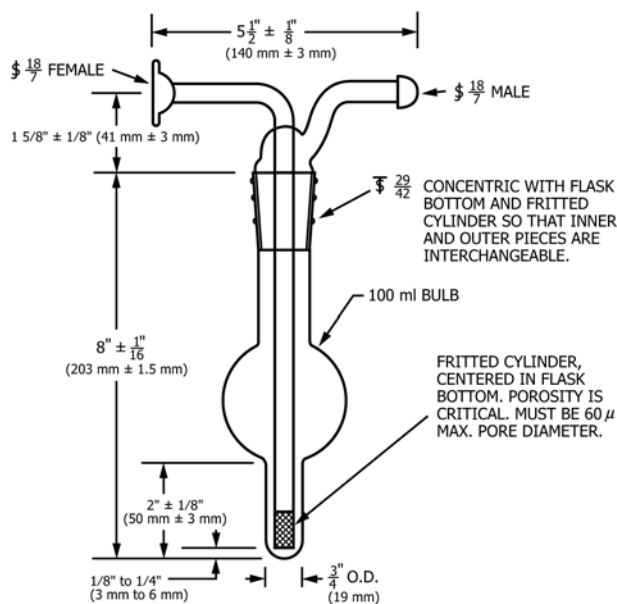

FIG. 1 Fritted Bubbler for Sampling Combined Nitrogen Oxides

⁴ *Reagent Chemicals, American Chemical Society Specifications*, American Chemical Society, Washington, DC. For suggestions on the testing of reagents not listed by the American Chemical Society, see *Analar Standards for Laboratory Chemicals*, BDH Ltd., Poole, Dorset, U.K., and the *United States Pharmacopeia and National Formulary*, U.S. Pharmacopeial Convention, Inc. (USPC), Rockville, MD.